

PUMP COVER

To suit pumps fitted with electronic controllers

- ❑ Pump Cover for Pumps
- ❑ One size suits DAB or BIANCO Electronic Pumps
- ❑ Sturdy 2 piece design – base and lid
- ❑ Protects your pumps from the elements
- ❑ Base keeps pump off the ground
- ❑ Cut-out slots for inlet and outlet piping
- ❑ Ventilation holes in base and lid
- ❑ Lid screw-fixes to base to prevent child tampering
- ❑ Colour: Beige
- ❑ Length: 720mm, Width: 420mm, Height: 520mm

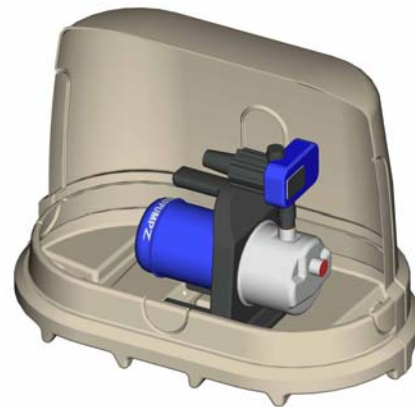
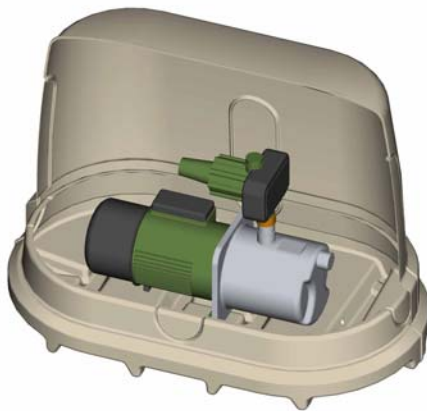

Model No: WHI-PUMPCOVER
Net Price: \$140.00 inc.gst

COVER YOUR PUMPS FROM THE ELEMENTS

To extend the working life of your pump it is recommended that all pumps be covered from the elements.