

K SINGLE IMPELLER PUMPS



Single impeller centrifugal pump designed for domestic, civil, industrial and agricultural installations and for decanting, mixing and irrigating uses.

Cast iron pump body and motor support.

Technopolymer or cast iron impeller as indicated in the TECHNICAL DATA table.

Stainless steel driving shaft. Carbon/ceramic mechanical seal.

Asynchronous, closed motor, cooled by external ventilation. Built-in thermal and current overload protection and a capacitor permanently on in the single-phase version. For the protection of the three-phase motor it is advisable

to use a suitable overload protection complying with the regulations in force.

Operating range: from 1.8 to 192 m³/h with head up to 83 metres.

Pumped liquid characteristics: clean, free from solids or abrasive substances, not viscous, not aggressive, not crystallised, chemically neutral and close to the characteristics of water.

Maximum ambient temperature: + 40°C

Protection level: IP 44

Terminal board protection level: IP 55

Insulation class: F

TECHNICAL DATA

MODEL	ELECTRICAL DATA						
	VOLTAGE 50 Hz	P1 MAX kW	P2 NOMINAL		In A	CAPACITOR	
			kW	HP		µF	Vc
K 20/41 M	1x220-240 V~	0,65	0,37	0,5	3	10	450
K 20/41 T	3x230-400 V~	0,64	0,37	0,5	2,3-1,3	-	-
K 30/70 M	1x220-240 V~	1,3	0,75	1	6	20	450
K 30/70 T	3x230-400 V~	1,2	0,75	1	4,3-2,5	-	-
K 30/100 M	1x220-240 V~	1,6	1,1	1,5	8	31,5	450
K 30/100 T	3x230-400 V~	1,63	1,1	1,5	5,5-3	-	-
K 36/100 M	1x220-240 V~	2,1	1,85	2,5	8,8	40	450
K 36/100 T	3x230-400 V~	2	1,85	2,5	6,9-4	-	-
K 12/200 M	1x220-240 V~	1,05	0,75	1	4,6	20	450
K 12/200 T	3x230-400 V~	1,02	0,75	1	3,6-2,1	-	-
K 36/200 T	3x230-400 V~	3	2,2	3	9-5,2	-	-
K 40/200 T	3x230-400 V~	3,5	3	4	11,1-6,4	-	-
K 55/200 T	3x230-400 V~	4,9	4	5,5	16,3-9,4	-	-
K 14/400 M	1x220-240 V~	2,1	1,85	2,5	9,5	40	450
K 14/400 T	3x230-400 V~	2,1	1,85	2,5	7,4	-	-
K 11/500 T	3x230-400 V~	2,6	2,2	3	9,1-5,8	-	-
K 18/500 T	3x230-400 V~	3,4	3	4	10,2-5,9	-	-
K 28/500 T	3x230-400 V~	4,5	4	5,5	14,7-8,5	-	-
K 40/400 T	3x400 V ~ Δ*	7	5,5	7,5	11,5	-	-
K 50/400 T	3x400 V ~ Δ*	9,4	7,5	10	15	-	-
K 30/800 T	3x400 V ~ Δ*	8,3	7,5	10	14	-	-
K 40/800 T	3x400 V ~ Δ*	11	9,2	12,5	18	-	-
K 50/800 T	3x400 V ~ Δ*	12,75	11	15	20,5	-	-
K 20/1200 T	3x400 V ~ Δ*	8,9	7,5	10	15,4	-	-
K 25/1200 T	3x400 V ~ Δ*	10	9,2	12,5	18	-	-
K 35/1200 T	3x400 V ~ Δ*	11,4	11	15	19,3	-	-

* Star (Δ) starting is possible

MODEL	MAX OPERATING PRESSURE	IMPELLER MATERIAL	LIQUID TEMPERATURE RANGE
K 20/41	6 bar (600 kPa)	TECHNOPOLYMER A	from -10°C to +50°C
K 30/70	6 bar (600 kPa)	TECHNOPOLYMER A	from -10°C to +50°C
K 30/100	6 bar (600 kPa)	TECHNOPOLYMER A	from -10°C to +50°C
K 36/100	6 bar (600 kPa)	TECHNOPOLYMER A	from -10°C to +50°C
K 12/200	6 bar (600 kPa)	TECHNOPOLYMER A	from -10°C to +50°C
K 36/200	8 bar (800 kPa)	TECHNOPOLYMER A	from -10°C to +50°C
K 40/200	8 bar (800 kPa)	TECHNOPOLYMER A	from -10°C to +50°C
K 55/200	8 bar (800 kPa)	TECHNOPOLYMER B	from -15°C to +110°C
K 14/400	6 bar (600 kPa)	CAST IRON 200 UNI ISO 185	from -15°C to +110°C
K 11/500	8 bar (800 kPa)	CAST IRON 200 UNI ISO 185	from -15°C to +110°C
K 18/500	8 bar (800 kPa)	CAST IRON 200 UNI ISO 185	from -15°C to +110°C
K 28/500	8 bar (800 kPa)	CAST IRON 200 UNI ISO 185	from -15°C to +110°C
K 40/400	10 bar (1000 kPa)	CAST IRON 200 UNI ISO 185	from -15°C to +110°C
K 50/400	10 bar (1000 kPa)	CAST IRON 200 UNI ISO 185	from -15°C to +110°C
K 30/800	10 bar (1000 kPa)	CAST IRON 200 UNI ISO 185	from -15°C to +110°C
K 40/800	10 bar (1000 kPa)	CAST IRON 200 UNI ISO 185	from -15°C to +110°C
K 50/800	10 bar (1000 kPa)	CAST IRON 200 UNI ISO 185	from -15°C to +110°C
K 20/1200	10 bar (1000 kPa)	CAST IRON 200 UNI ISO 185	from -15°C to +110°C
K 25/1200	10 bar (1000 kPa)	CAST IRON 200 UNI ISO 185	from -15°C to +110°C
K 35/1200	10 bar (1000 kPa)	CAST IRON 200 UNI ISO 185	from -15°C to +110°C

HYDRAULIC DATA

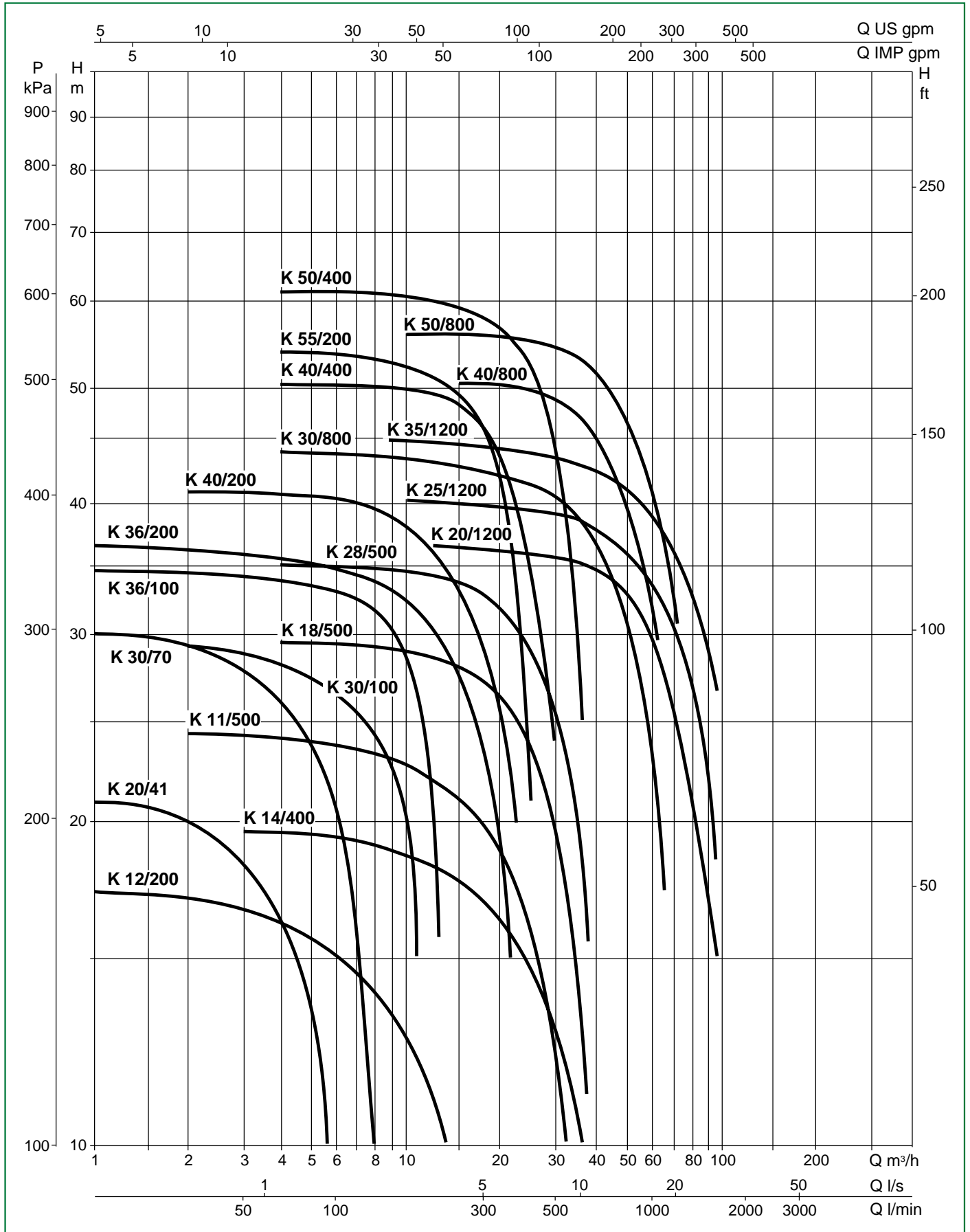

DIMENSIONS AND WEIGHTS

K 20/41 - 30/70

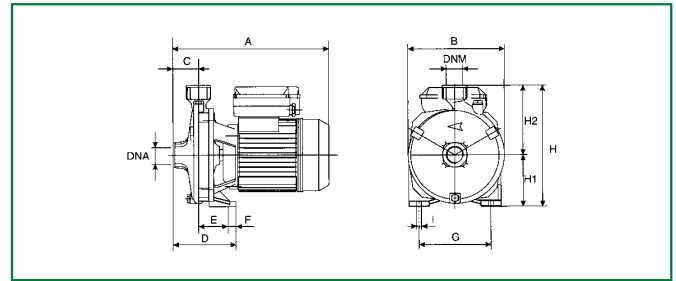

K 30-36/100

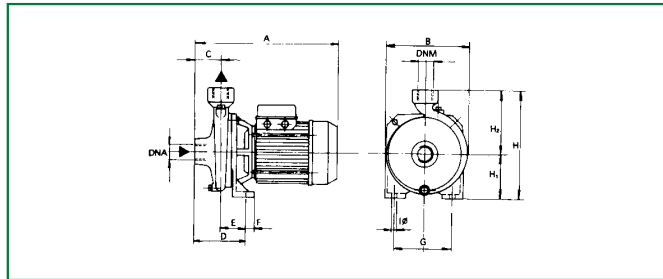

K 12/200

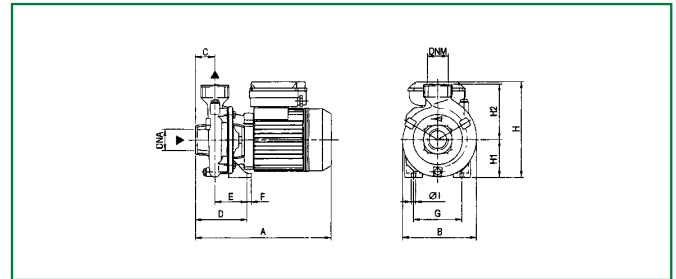

K 36-40-55/200 - 14/400 - 11-18-28/500

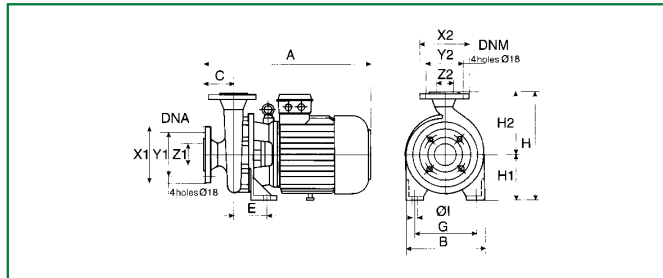

K 40-50/400 - 30-40-50/800 - 20-25-35/1200

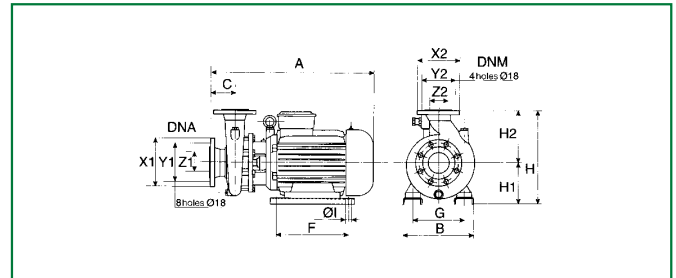

MODEL	A	B	C	E	G	Ø1	H	H1	DNA	DNM	WEIGHT Kg
K 20/41	275	160	50	50	110	9	205	85	1" G	1" G	10
K 30/70	300	185	50	58	140	9	235	100	1" G	1" G	14,5
K 30/100	333	200	50	64	140	9	255	105	1 1/2" G	1" G	18,5
K 36/100	333	200	50	64	140	9	255	105	1 1/2" G	1" G	19,7
K 12/200	312	169	45	69	110	9	218	85	1 1/2" G	1 1/2" G	13,8
K 36/200	425	250	55	86	175	14	320	135	2" G	1 1/4" G	32,1
K 40/200	425	250	55	86	175	14	320	135	2" G	1 1/4" G	33,9
K 55/200	425	250	55	86	175	14	320	135	2" G	1 1/4" G	33,9
K 14/400 M	430	200	62	74	120	11	270	105	2" G	2" G	24,5
K 14/400 T	358	200	62	74	120	11	270	105	2" G	2" G	22
K 11/500	440	240	62	100	155	14	312	132	2 1/2" G	2" G	33,2
K 18/500	440	240	62	100	155	14	312	132	2 1/2" G	2" G	35,6
K 28/500	440	240	62	100	155	14	312	132	2 1/2" G	2" G	39,6
K 40/400	560	273	100	110	212	14	360	160	65	50	78,8
K 50/400	560	273	100	110	212	14	360	160	65	50	78,8
K 30/800	600	273	100	110	212	14	385	160	80	65	90,2
K 40/800	600	273	100	110	212	14	385	160	80	65	95
K 50/800	600	273	100	110	212	14	385	160	80	65	104,3
K 20/1200	600	273	100	110	212	14	385	160	80	65	88
K 25/1200	600	273	100	110	212	14	385	160	80	65	94
K 35/1200	600	273	100	110	212	14	385	160	80	65	100



K 40/50 M

K TWIN IMPELLER PUMPS



Twin impeller centrifugal pump designed for use in pressurisation units for water supply systems for domestic, civil and industrial use. Suitable for sprinkling irrigation and other water supply applications. Cast iron pump body and motor support. Technopolymer impeller.

Stainless steel driving shaft. Carbon/ceramic mechanical seal.

Asynchronous, closed motor, cooled by external ventilation.

Built-in thermal and current overload protection and a capacitor permanently on in the single-phase version. For the protection of the three-phase motor it is advisable to use a suitable overload protection complying with the regulations in force.

Operating range: from 1.5 to 30 m³/h with head up to 97 metres.

Pumped liquid characteristics: clean, free from solids or abrasive substances, not viscous, not aggressive, not crystallised, chemically neutral and close to the characteristics of water.

Maximum ambient temperature: + 40°C

Protection level: IP 44

Terminal board protection level: IP 55 over 4 kW

Insulation class: F

TECHNICAL DATA

MODEL	ELECTRICAL DATA						
	VOLTAGE 50 Hz	P1 MAX kW	P2 NOMINAL kW HP		In A	CAPACITOR µF Vc	
K 35/40 M	1x220-240 V ~	1,2	0,75	1	5,4	20	450
K 35/40 T	3x230-400 V ~	1,7	0,75	1	3,8-2,2	-	-
K 45/50 M	1x220-240 V ~	1,86	1,1	1,5	8,3	31,5	450
K 45/50 T	3x230-400 V ~	1,96	1,1	1,5	6-3,5	-	-
K 55/50 M	1x220-240 V ~	2,7	1,85	2,7	12,8	40	450
K 55/50 T	3x230-400 V ~	2,73	1,85	2,5	8,4-4,8	-	-
K 35/100 M	1x220-240 V ~	1,56	1,1	1,5	7,1	25	450
K 35/100 T	3x230-400 V ~	1,56	1,1	1,5	5,36-3,1	-	-
K 40/100 M	1x220-240 V ~	2	1,85	2,5	9	40	450
K 40/100 T	3x230-400 V ~	2	1,85	2,5	6,2-3,6	-	-
K 55/100 T	3x230-400 V ~	3,9	2,2	3	11,6-6,7	-	-
K 66/100 T	3x230-400 V ~	4,7	3	4	14,6-8,4	-	-
K 90/100 T	3x230-400 V ~	5,4	4	5,5	16,5-9,5	-	-
K 70/300 T	3x400 V ~ Δ*	7,1	5,5	7,5	12,9	-	-
K 80/300 T	3x400 V ~ Δ*	9,9	7,5	10	15	-	-
K 70/400 T	3x400 V ~ Δ*	10,7	9,2	12,5	18	-	-
K 80/400 T	3x400 V ~ Δ*	12,5	11	15	21	-	-

* Star (Δ) starting is possible

MODEL	MAX OPERATING PRESSURE	IMPELLER MATERIAL	LIQUID TEMPERATURE RANGE
K 35/40	6 bar (600 kPa)	TECNOPOLIMERO A	from -10°C to +50°C
K 45/50	8 bar (800 kPa)	TECHNOPOLYMER A	from -10°C to +50°C
K 55/50	8 bar (800 kPa)	TECHNOPOLYMER B	from -15°C to +110°C
K 35/100	6 bar (600 kPa)	TECHNOPOLYMER A	from -10°C to +50°C
K 40/100	6 bar (600 kPa)	TECHNOPOLYMER A	from -10°C to +50°C
K 55/100	10 bar (1000 kPa)	TECHNOPOLYMER A	from -10°C to +50°C
K 66/100	10 bar (1000 kPa)	TECHNOPOLYMER B	from -15°C to +110°C
K 90/100	12 bar (1200 kPa)	TECHNOPOLYMER B	from -15°C to +110°C
K 70/300	12 bar (1200 kPa)	TECHNOPOLYMER B	from -15°C to +110°C
K 80/300	12 bar (1200 kPa)	TECHNOPOLYMER B	from -15°C to +110°C
K 70/400	12 bar (1200 kPa)	TECHNOPOLYMER B	from -15°C to +110°C
K 80/400	12 bar (1200 kPa)	TECHNOPOLYMER B	from -15°C to +110°C

HYDRAULIC DATA

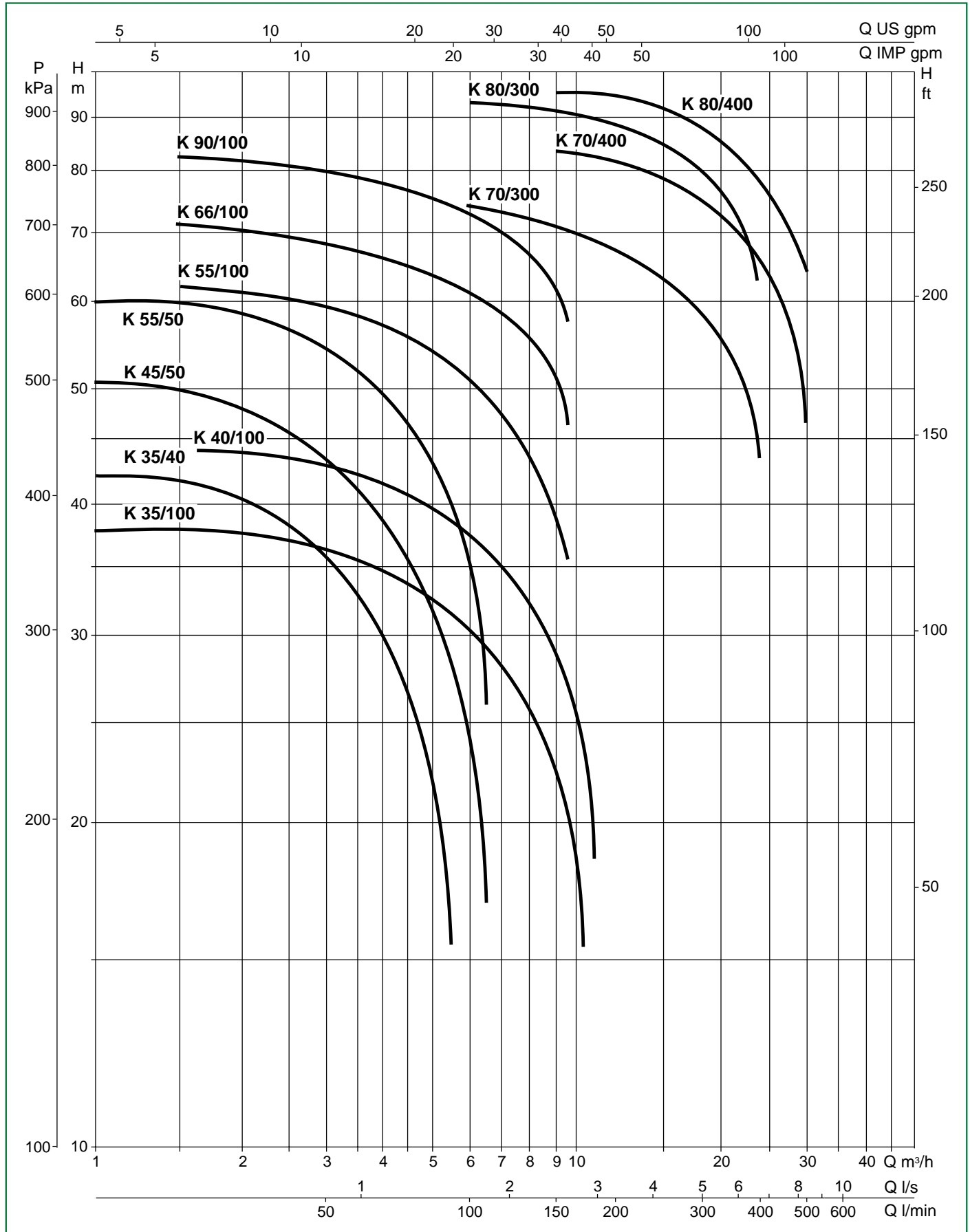

DIMENSIONS AND WEIGHTS

K 35/40 - K 45/50 - K 55-50

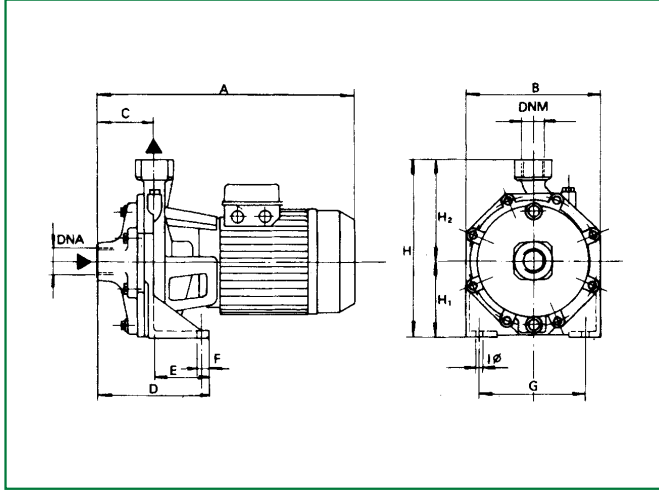

K 35/100 - K 40/100

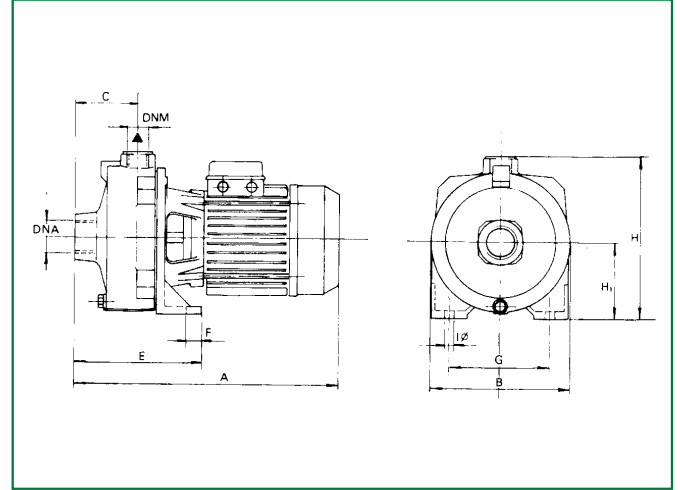

K 55/100 - K 66/100 - K 90/100

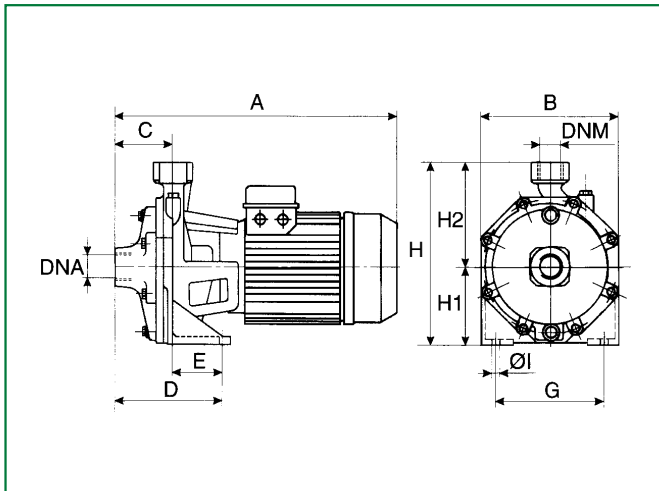

K 70/300 - K 80/300 - K 70/400 - K 80/400

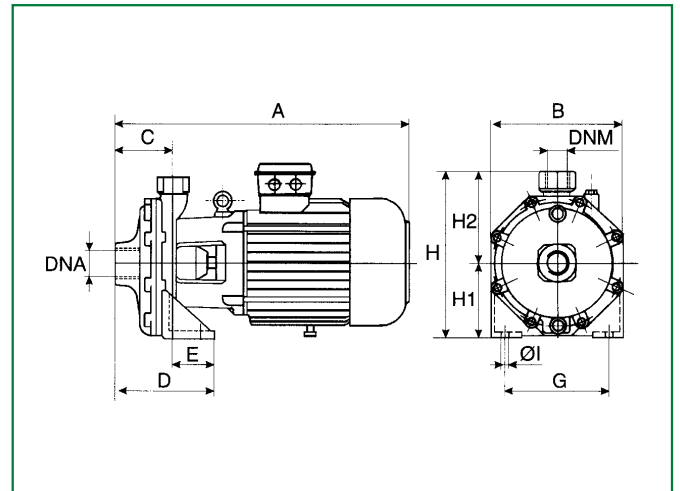

MODEL	A	B	C	D	E	F	G	ØI	H	H1	H2	DNA	DNM	WEIGHT Kg
K 35/40	342	180	76	148	72	15	148	9,5	235	100	135	1" G	1" G	15,9
K 45/50	370	210	75	144	69	15	165	11,5	268	118	150	1 1/4" G	1" G	23,3
K 55/50	370	210	75	114	69	15	165	11,5	268	118	150	1 1/4" G	1" G	23,8
K 35/100	387	205	88	-	179	20	145	11	233	108	-	1 1/2" G	1" G	21,5
K 40/100 M	461	205	88	-	179	20	145	11	233	108	-	1 1/2" G	1" G	25,9
K 40/100 T	387	205	88	-	179	20	145	11	233	108	-	1 1/2" G	1" G	22
K 55/100	450	256	88	160	72	18	200	14	312,5	140	172,5	1 1/2" G	1" G	37,1
K 66/100	450	256	88	160	72	18	200	14	312,5	140	172,5	1 1/2" G	1" G	39,7
K 90/100	450	256	88	160	72	18	200	14	312,5	140	172,5	1 1/2" G	1" G	43
K 70/300	595	270	122	182	60	20	210	14	340	160	180	2" G	1 1/4" G	72
K 80/300	595	270	122	182	60	20	210	14	340	160	180	2" G	1 1/4" G	78,5
K 70/400	635	270	122	182	60	20	210	14	340	160	180	2" G	1 1/4" G	74
K 80/400	635	270	122	182	60	20	210	14	340	160	180	2" G	1 1/4" G	78